

# Series E (ESD/EFT) Transient Protected Connectors

These fully integrated connectors and adapters provide protection from Electro Static Discharge (ESD) and Electronically Fast Transients (EFT) that can damage or even destroy your equipment. The connectors are designed to meet various IEC 61000-4-21, EN 61000-4-2 and IEC 61000-4 standards, and are offered in a wide range of clamping voltages to fit your specific application. The connectors have integrated ESD transient voltage suppressors from Littelfuse®, are available in industry standard sizes and are “drop in” replacements for unprotected connectors.

They are available with various capacitance levels to condition your signals to handle EMI issues at the same time or with as little as a 0.05 pF to protect the integrity of your signal in high speed or digital applications.

## Features

- **ESD/EFT protection at the I/O ports** – Prevents the transients from entering the system before they can cause harm or create EMI problems.
- **Low ground impedance** – The metallic shell provides minimal impedance to direct the damaging transient spikes to ground, which is essential for proper protection.
- **Removal of ground traces from the board** – This eliminates potential line-to-line noise problems and spark-overs between ground and signal lines.
- **Complete protection** – All lines, including ground lines, have bi-directional protection.
- **Efficient space utilization** – Standard footprints save valuable board space in terms of not only components, but also extra ground traces.
- **Fewer components** – Reduces total number of components purchased, stocked, placed and tested; yielding the savings of all the hidden costs involved in these activities, while reducing your supplier base.
- **Available capacitance** – Available with various capacitance values to supply low pass properties along with the transient protection, thus supplying ESD/EFT and EMI protection all in one complete package. The metal shell also provides EMI shielding of system. Parts are available with capacitance values less than 50 pF for digital and very high speed signal lines.



## Typical Time-Voltage Curves

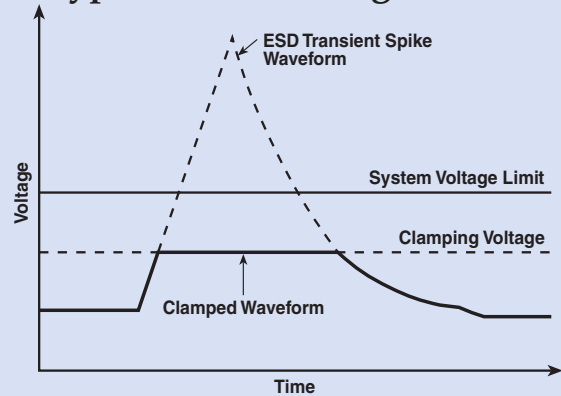

Typical Time-Voltage Curve of Transient Spike on Integrated Protected Connector with Capacitance (Parts with Working Voltage Code starting with 0)

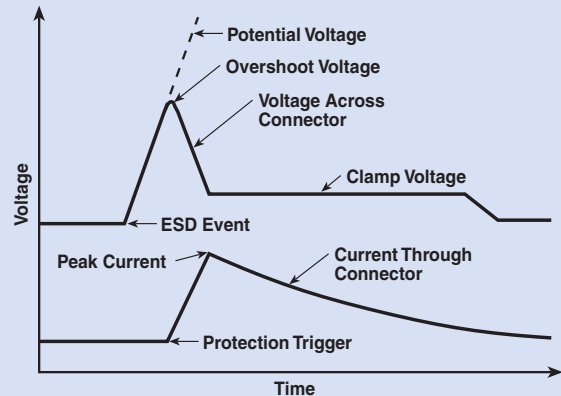

Typical Time-Voltage Curve of Low Capacitance Integrated Protection (Parts with Working Voltage Code starting with P)

## Mechanical Specifications

- Front Shell . . . . . Steel, tin plated
- Housing . . . . . 94V-0 rated thermoplastic, black
- Eyelets . . . . . Brass, tin plated
- Threaded Inserts . . . . . Zinc
- Boardlocks . . . . . Copper alloy, tin-lead plated
- Pin Contacts . . . . . Brass
- Socket Contacts . . . . . Phosphor Bronze
- Contact Plating . . . . . Duplex plated as follows: 15uin (.38um) gold on mating end, with entire contact 50uin (1.27um) min. nickel underplated and flash gold finish.
- Current Rating . . . . . 5 Amp per pin
- Operating Temp . . . . . -55°C to +125°C

# Series E (ESD/EFT) Transient Protected Connectors

## Ordering Information

Example: **56-E04-005-5-T**

This part number represents a Series E connector with a shell size of 9 and a socket to right angle configuration. The maximum working voltage is 5.5 VDC and the connector has a .590" footprint with 4-40 threads.

<b>56</b>	<b>E</b>	<b>0</b>	<b>4</b>	<b>005</b>	<b>5</b>	<b>T</b>
<b>Integrated D-sub Connectors</b>	<b>Series E (ESD/EFT) Connectors</b>			<b>Contact Type/Termination</b>	<b>Working Voltage Code</b>	<b>Footprint (right angle connectors only)</b>
		<b>Shell Size/Number of Contacts</b>			See table below. (Use 3-digit code that matches your electrical requirements)	
		0 - 9 size 1 - 15 size 2 - 25 size 3 - 37 size		1 - Pin to solder cup 2 - Pin to right angle 3 - Socket to straight PCB 4 - Socket to right angle 5 - Adapter (pin to socket) 6 - Socket to solder cup 7 - Pin to straight PCB		3 - .318" 4 - .405" 5 - .590"
						<b>Mounting or Hardware Options</b>
						- .120 thru-hole and 15µ" gold <b>3G</b> - 30µ" gold <b>5G</b> - 50µ" gold
						<b>SC and Straight PCBs (only)</b>
						<b>TIB</b> - 4-40 thread on rear of flange <b>TIF</b> - 4-40 thread on front of flange <b>MIB</b> - M3 thread on rear of flange
						<b>GBL6</b> - for .062" boards <b>JS</b> - Jack screws
						<b>Right Angles and Adapters (only)</b>
						- No GBL attached <b>GL</b> - Includes grounding board lock <b>T</b> - 4-40 threads <b>GB</b> - No board locks <b>J</b> - Jack screws <b>M</b> - M3 thread <b>GJ</b> - GL and jack screws

## Transient Voltage Protection with Capacitance

Immunity to IEC 61000-4-2 (ESD) up to level 4 and IEC 61000-4-4 (EFT) air and contact discharge specifications.

Working Voltage Code	Max. Working Voltage VDC	Max. Working Voltage VAC	Clamp Voltage 8 x 20 µs	Peak Current 8 x 20 µs	V breakdown 1 ma	Energy (J) 10 x 100 µs	Typical Cap. pF at 1 MHz	
003	3.5	2.5	10.0@5A	120	5 (3.7-7.0)	0.3	2200	
005	5.5	4.0	15.5@5A	120	8 (7.1-9.3)	0.3	1600	
009	9.0	6.5	20.0@2A	40	12 (11-14)	0.1	450	
012	12.0	9.0	25.0@2A	40	16 (14-18.5)	0.1	350	
014	14.0	10.0	30.0@5A	120	18 (15.9-20.3)	0.3	480	
018	18.0	14.0	40.0@5A	120	25 (22-28)	0.3	450	
026	26.0	20.0	58.0@5A	100	34 (29.5-38.5)	0.3	190	
030	30.0	25.0	65.0@2A	30	42 (37-46)	0.1	80	
	>30.0	>25.0	Please consult factory for availability					

**Notes:** Consult factory for custom capacitance values. Typical leakage at 25°C is <25 µA  
Maximum leakage 50 µA at V<sub>m(DC)</sub>

## Transient Voltage Protection without Significant Capacitance

Immunity to IEC 61000-4-2 (ESD) up to Level 4 air and contact discharge. Excellent for digital, high speed and high frequency signals.

Working Voltage Code	Max. Working Voltage (V) DC	Clamp Voltage		Trigger Voltage	Leakage (A) Current	Typical Cap. at 1 MHz
		Typical	Maximum			
P24	24.0	150.0	80.0	1000	<1.0 nA	0.05 pF

## Board Layouts

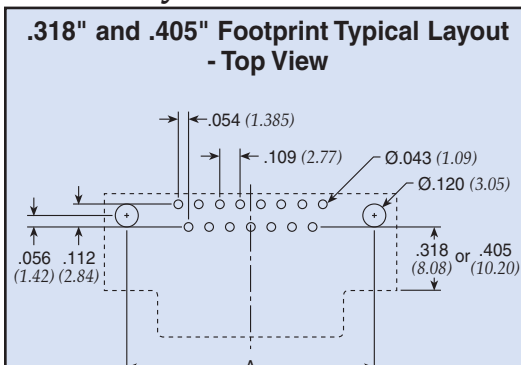
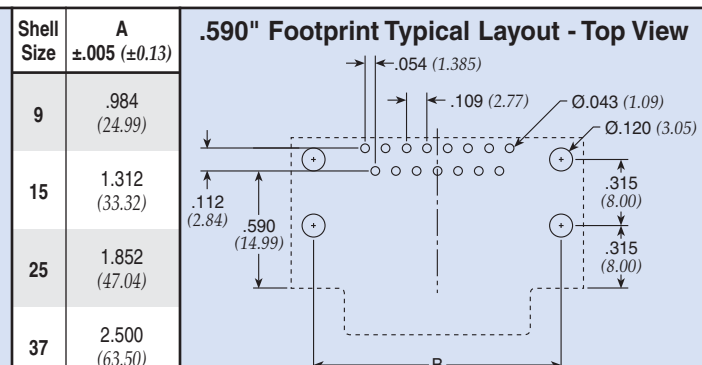
.318" and .405" Footprint Typical Layout - Top View		Shell Size	A ±.005 (±0.13)	.590" Footprint Typical Layout - Top View		Shell Size	B ±.005 (±0.13)
		9	.984 (24.99)			9	.984 (24.99)
		15	1.312 (33.32)			15	1.312 (33.32)
		25	1.852 (47.04)			25	1.852 (47.04)
		37	2.500 (63.50)			37	2.500 (63.50)

Dimensions in inches (mm)

# Series E (ESD/EFT) Transient Protected Connectors

### Pin Contact (plug) Straight PC Mount

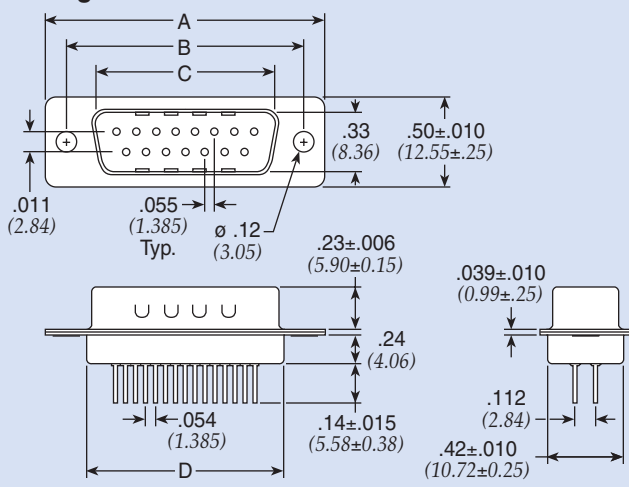

### 90° PC Mount

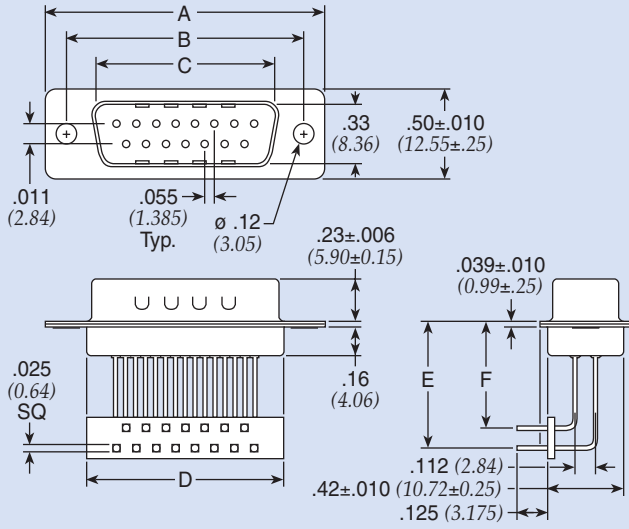

Size	A	B	C	D
9	1.213±.015 (30.81±0.38)	.984±.005 (24.99±0.13)	.667±.010 (16.92±0.25)	.755 (19.18)
15	1.541±.015 (39.14±0.38)	1.312±.005 (33.32±0.13)	.994±.010 (25.25±0.25)	1.083 (27.51)
25	2.088±.015 (53.04±0.38)	1.852±.005 (47.04±0.13)	1.534±.010 (38.96±0.25)	1.614 (41.00)
37	2.73±.015 (69.32±0.38)	2.50±.005 (63.50±0.13)	2.18±.010 (55.42±0.25)	2.27 (57.71)

Footprint	E	F
.318	.430 (10.92)	.318 (8.08)
.405	.517 (13.13)	.405 (10.29)
.590	.700 (17.83)	.590 (14.99)

Dimensions in inches (mm)

### Socket Contact (receptacle) Straight PC Mount

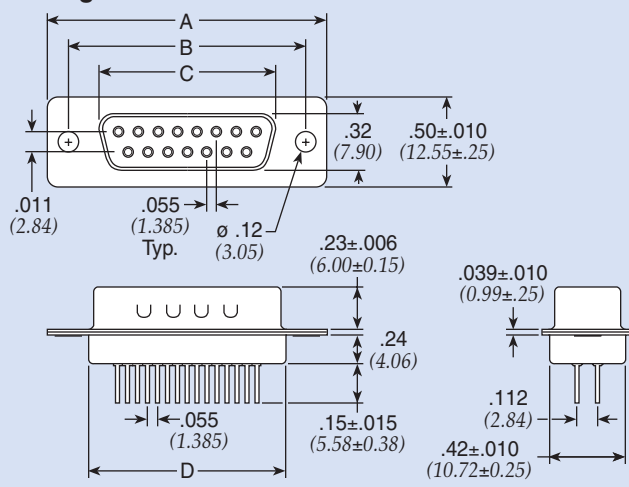

### 90° PC Mount

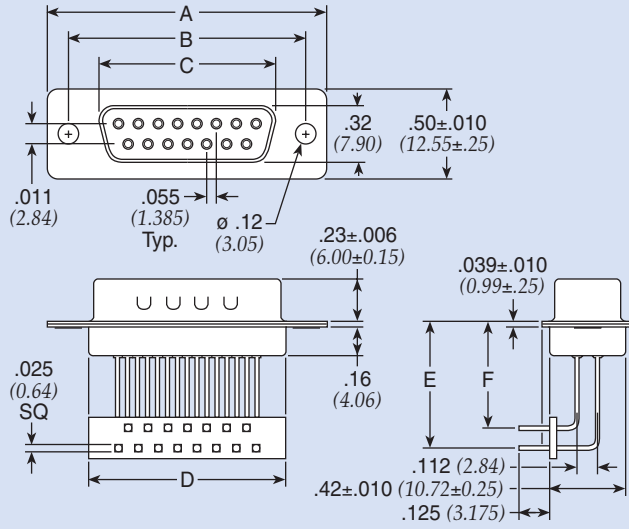

Size	A	B	C	D
9	1.213±.015 (30.81±0.38)	.984±.005 (24.99±0.13)	.643±.010 (16.33±0.25)	.755 (19.18)
15	1.541±.015 (39.14±0.38)	1.312±.005 (33.32±0.13)	.971±.010 (24.66±0.25)	1.083 (27.51)
25	2.088±.015 (53.04±0.38)	1.852±.005 (47.04±0.13)	1.511±.010 (38.38±0.25)	1.614 (41.00)
37	2.73±.015 (69.32±0.38)	2.50±.005 (63.50±0.13)	2.16±.010 (54.84±0.25)	2.27 (57.71)

Footprint	E	F
.318	.430 (10.92)	.318 (8.08)
.405	.517 (13.13)	.405 (10.29)
.590	.700 (17.83)	.590 (14.99)

Dimensions in inches (mm)

# Series E (ESD/EFT) Transient Protected Connectors

## Pin Contact (plug) Solder Cup Termination

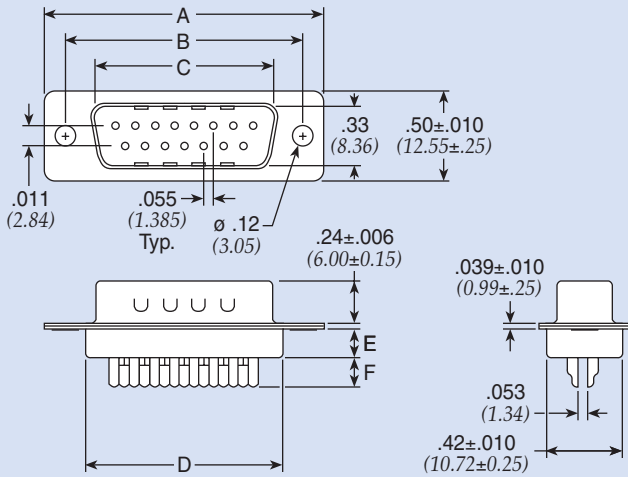

## Socket Contact (receptacle) Solder Cup Termination

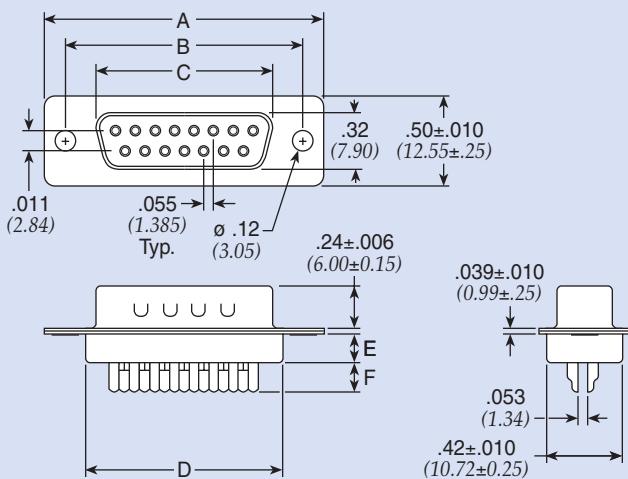

Size	A	B	C	D	E	F
9	1.213±.015 (30.81±0.38)	.984±.005 (24.99±0.13)	.643±.010 (16.33±0.25)	.755 (19.18)	.16 (4.06)	.16 (4.06)
15	1.541±.015 (39.14±0.38)	1.312±.005 (33.32±0.13)	.971±.010 (24.66±0.25)	1.083 (27.51)	.16 (4.06)	.16 (4.06)
25	2.089±.015 (53.04±0.38)	1.852±.005 (47.04±0.13)	1.511±.010 (38.38±0.25)	1.615 (41.00)	.16 (4.06)	.16 (4.06)
37	2.73±.015 (69.32±0.38)	2.50±.005 (63.50±0.13)	2.16±.010 (54.84±0.25)	2.27 (57.71)	.16 (4.06)	.16 (4.06)

Dimensions in inches (mm)

## Pin - Socket Adapter

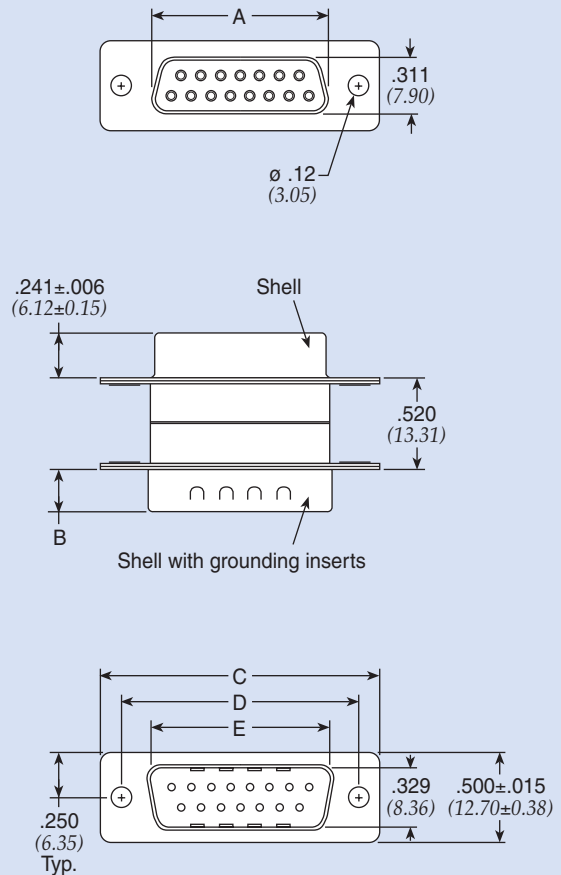

Size	A	B	C	D	E
9	.642 (16.31)	.233±.006 (5.92±.15)	1.213±.015 (30.81±.38)	.984 (24.99)	.667 (16.94)
15	.970 (24.64)	.233±.006 (5.92±.15)	1.541±.015 (39.14±.38)	1.312 (33.33)	.995 (25.27)
25	1.511 (38.38)	.228±.006 (5.80±.15)	2.088±.015 (53.04±.38)	1.852 (47.05)	1.532 (38.92)
37	2.158 (54.82)	.228±.006 (5.80±.15)	2.729±.015 (69.32±.38)	2.500 (63.50)	2.183 (55.45)

Dimensions in inches (mm)